

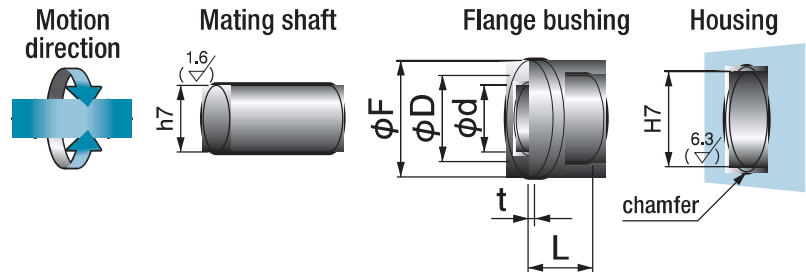

Specify Part No. by required I.D. and length.
(e.g.) I.D. is 30mm and length is 40mm.

30F - 3040 Parts No.



- Use Oiles 300 in lubrication oil or with periodic lubrication.

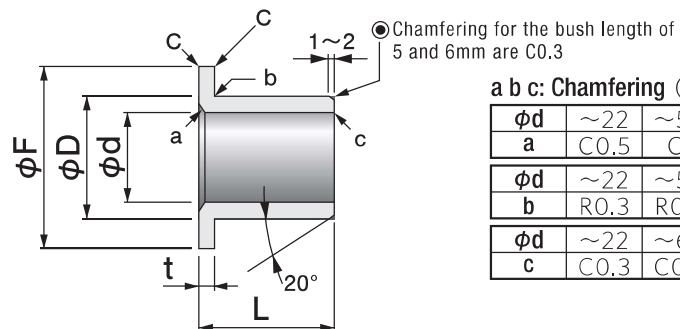

a b c: Chamfering (mm)

ϕd	~22	~50	~60
a	C0.5	C1	C1.5
ϕd	~22	~50	~60
b	R0.3	R0.5	R1
ϕd	~22	~60	
c	C0.3	C0.5	

I.D.		O.D.		Flange			Length L Tolerance -0.3											I.D. tolerance after press fitting (reference)		
ϕd	Tolerance	ϕD	Tolerance	ϕF	Tolerance	t	Tolerance	5	8	10	12	15	20	25	30	40	50		60	80
5	+0.058 +0.040	8	+0.034 +0.019	11	0 -0.3	1.5	0 -0.1	0505	0508											+0.030 +0.012
6	+0.058 +0.040	10	+0.034 +0.019	14	0 -0.3	2	0 -0.1		0608	0610										+0.030 +0.012
8	+0.068 +0.046	12	+0.041 +0.023	20	0 -0.3	2	0 -0.1			0810	0812	0815								+0.034 +0.012
10	+0.068 +0.046	16	+0.041 +0.023	23	0 -0.3	3	0 -0.1			1010	1012	1015	1020							+0.045 +0.023
12	+0.068 +0.041	18	+0.041 +0.023	25	0 -0.3	3	0 -0.1			1210	1212	1215	1220	1225						+0.045 +0.018
14	+0.068 +0.041	20	+0.049 +0.028	27	0 -0.3	3	0 -0.1			1410	1412	1415	1420	1425						+0.040 +0.013
15	+0.068 +0.041	21	+0.049 +0.028	28	0 -0.3	3	0 -0.1			1510	1512	1515	1520	1525	1530					+0.040 +0.013
16	+0.068 +0.041	22	+0.049 +0.028	29	0 -0.3	3	0 -0.1			1612	1615	1620	1625	1630						+0.040 +0.013
18	+0.068 +0.041	25	+0.049 +0.028	33	0 -0.3	3.5	0 -0.1				1815	1820	1825	1830						+0.040 +0.013
20	+0.088 +0.055	28	+0.049 +0.028	38	0 -0.3	4	0 -0.1				2015	2020	2025	2030	2040					+0.060 +0.027
22	+0.088 +0.055	30	+0.049 +0.028	40	0 -0.3	4	0 -0.1				2215	2220	2225	2230	2240					+0.060 +0.027
25	+0.088 +0.055	35	+0.059 +0.034	45	0 -0.3	5	0 -0.1				2515	2520	2525	2530	2540					+0.054 +0.021
28	+0.088 +0.055	38	+0.059 +0.034	48	0 -0.3	5	0 -0.1						2825	2830						+0.054 +0.021
30	+0.088 +0.055	40	+0.059 +0.034	50	0 -0.3	5	0 -0.1							3030	3040					+0.054 +0.021
32	+0.112 +0.073	42	+0.059 +0.034	52	0 -0.3	5	0 -0.1							3230	3240					+0.078 +0.039
35	+0.112 +0.073	45	+0.059 +0.034	60	0 -0.3	5	0 -0.1							3530	3540					+0.078 +0.039
40	+0.112 +0.073	50	+0.059 +0.034	65	0 -0.3	5	0 -0.1								4040	4050				+0.078 +0.039
45	+0.112 +0.073	55	+0.073 +0.041	70	0 -0.3	5	0 -0.1								4540	4550				+0.070 +0.031
50	+0.112 +0.073	60	+0.073 +0.041	75	0 -0.3	5	0 -0.1									5050	5060			+0.070 +0.031
55	+0.144 +0.098	70	+0.073 +0.041	85	0 -0.3	7.5	0 -0.1										5550	5560		+0.102 +0.056
60	+0.144 +0.098	75	+0.073 +0.041	90	0 -0.3	7.5	0 -0.1											6060	6080	+0.102 +0.056

※The I.D. tolerance after press fitting is for reference only.

▲ The dimensional tolerances are the values measured at +25°C.