

● Sliding surface consists of a plastic layer.

Specify Part No. by required thickness and width.
(e.g.) Thickness is 1.5mm and width is 90mm.

LFP - 1590

Parts No.

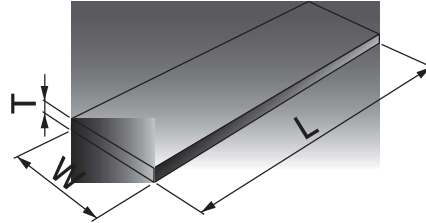

Parts No.	Thickness		Width	Length
	T	Tolerance	W	L
LFP-1080	1.0	-0.03 -0.13	80	500
LFP-1590	1.5	-0.03 -0.13	90	500
LFP-20100	2.0	-0.03 -0.13	100	500
LFP-25100	2.5	-0.03 -0.13	100	500

How to attach washers, plates

① Knock pin method (Thrust washer)

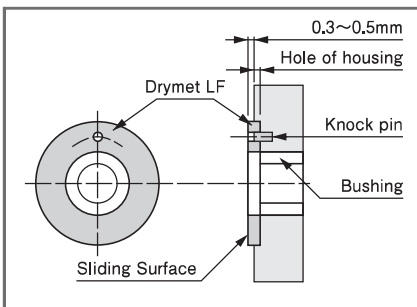

※Sliding surface consists of a plastic layer.

② Inlay method (Plate)

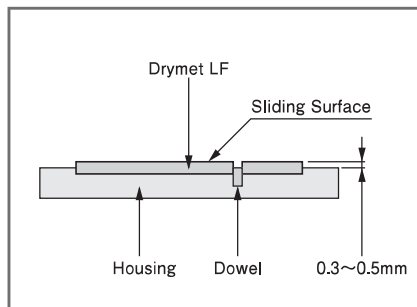

※Sliding surface consists of a plastic layer.

③ Flat head screw method

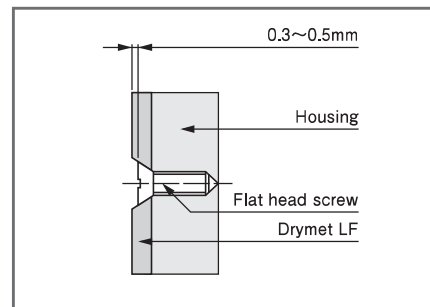

④ Using glue

In the case of (2), the washer and plate may be inserted with glue, not a knock pin. Synthetic epoxy plastic glue is suitable, though no glue is specified, in particular. Be careful because fitting with glue only may result in separation in some cases.