

Specify Part No. by required size.
(e.g.) Width is 50mm.

PAC 50 - 150 Parts No.

	Part name	Material
①	Table	SS400
②	Slide plate	2000
③	Slide seal*	NBR+SPCC
④	Adjustable push bolt	SCM435
⑤	Adjustable pull bolt	SCM435
⑥	Spring washers	SCM435
⑦	Set screw for seal*	SCM435
⑧	Grease nipple	S15C (C-PT1/8)
⑨	Spring pin	S60CM

※PAC30-90 does not have a slide seal and set screw for seal.

W=30, 40, 50, 60, 75

W=100, 125, 150

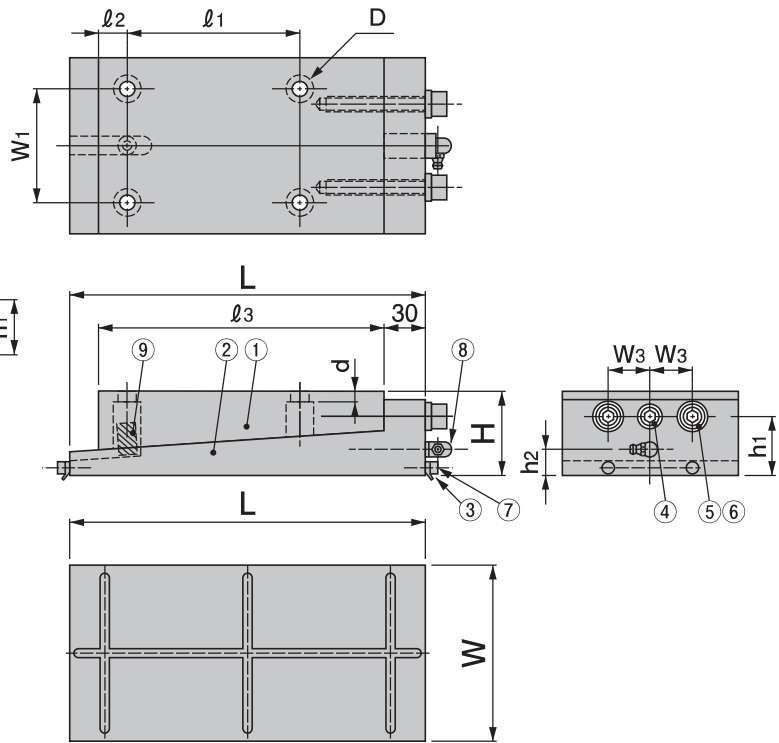
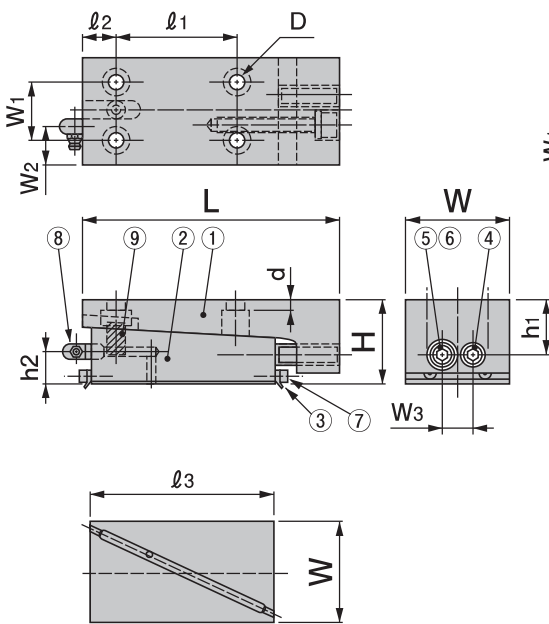

Parts No.	Width	Length	Height	D	W ₁	W ₂	W ₃	l ₁	l ₂	l ₃	h ₁	h ₂	d	Adjustable bolts	
	W	L	H											④	⑤
PAC30-90	30	80	30	(M6)	15	6.5	13	25	30	55	20.5	7.5	4.5	M 8×25	M 6×35
PAC40-100	40	90	40	(M6)	25	8	13	35	15	55	23.5	18	5	M10×30	M 6×40
PAC50-150	50	140	45	(M8)	30	15	16	65	20	100	28	20	5	M12×35	M 8×50
PAC60-160	60	150	50	(M10)	35	20	17	70	20	110	32	20	6	M12×35	M 8×50
PAC75-180	75	170	50	(M10)	45	25	17	85	25	130	33	20	6	M12×35	M 8×50
PAC100-250	100	250	60	(M12)	60	—	25	120	20	200	43	20	10	M16×40	M10×70
PAC125-250	125	250	60	(M12)	80	—	30	120	20	200	43	20	10	M16×40	M10×70
PAC150-300	150	300	70	(M16)	100	—	40	120	40	250	50	20	10	M20×40	M12×70