

PD73

Portable Type Deadweight Testers



Features

- The PD73, the portable type contributes for fast pressure measurement at arbitrary location.
- Standard comes with carrying case, level and horizontal adjustment.
- Pressure can also be measured by installing a test gauge instead of deadweight.
- Possible to carry around with filled oil.
- The pressure gauge can be easily mounted and dismounted from the mounting base with the quick fastening nut.
- JCSS Calibration Certification
- NKS Inspection Certificate and Pressure standard Inspection available.

Specifications

Type	Portable type
Operating fluid	Hydraulic fluid
Operation	Manual
Pressure range	1 to 5MPa (0.1%O.R. is not available for 1MPa and 2MPa.)
Accuracy	±0.1% of reading ±0.2% of reading
	Primary pressure measurement only. Secondary pressure measurement range covers lower outside range of primary pressure measurement range (10% of maximum rated pressure). Primary pressure measurement range: Range between 10% to maximum range of rated pressure Secondary pressure measurement range: Range between minimum to 10% of rated pressure
Body color	Pearl light green (±0.1%O.R.) Mustard yellow (±0.2%O.R.)
Body weight	5.7kg

Deadweight composition

Measurement range MPa			Effective sectional area cm ²	Deadweight MPa													Total	Net weight of deadweight Approx. kg		
Max.	Min.	Smallest graduation		Piston			Number of weights by value													
				0.05	0.1	0.2	0.005	0.01	0.02	0.05	0.1	0.2	0.3	0.5	1	2	5			
1 *		0.005	1/2	1			1	1	2	2	8							1.005	5	
2 *	0.05	0.01		1				1	2	2	2	8							2	10
3				1				1	2	2	2	1		5					3.1	16
5				1						1	2	1		9					5	26
10	0.1	0.05	1/4		1					1	2	1		1	9			10.05	26	
20	0.2					1						1	2	1		1	3	8	20.05	51
30	0.5	0.1	1/8			1					1	2	1	1	1	2	5	31.5	40	
50						1							1	2	1	1	1	2	9	51.5

*0.1%O.R. is not available.

Dimensions

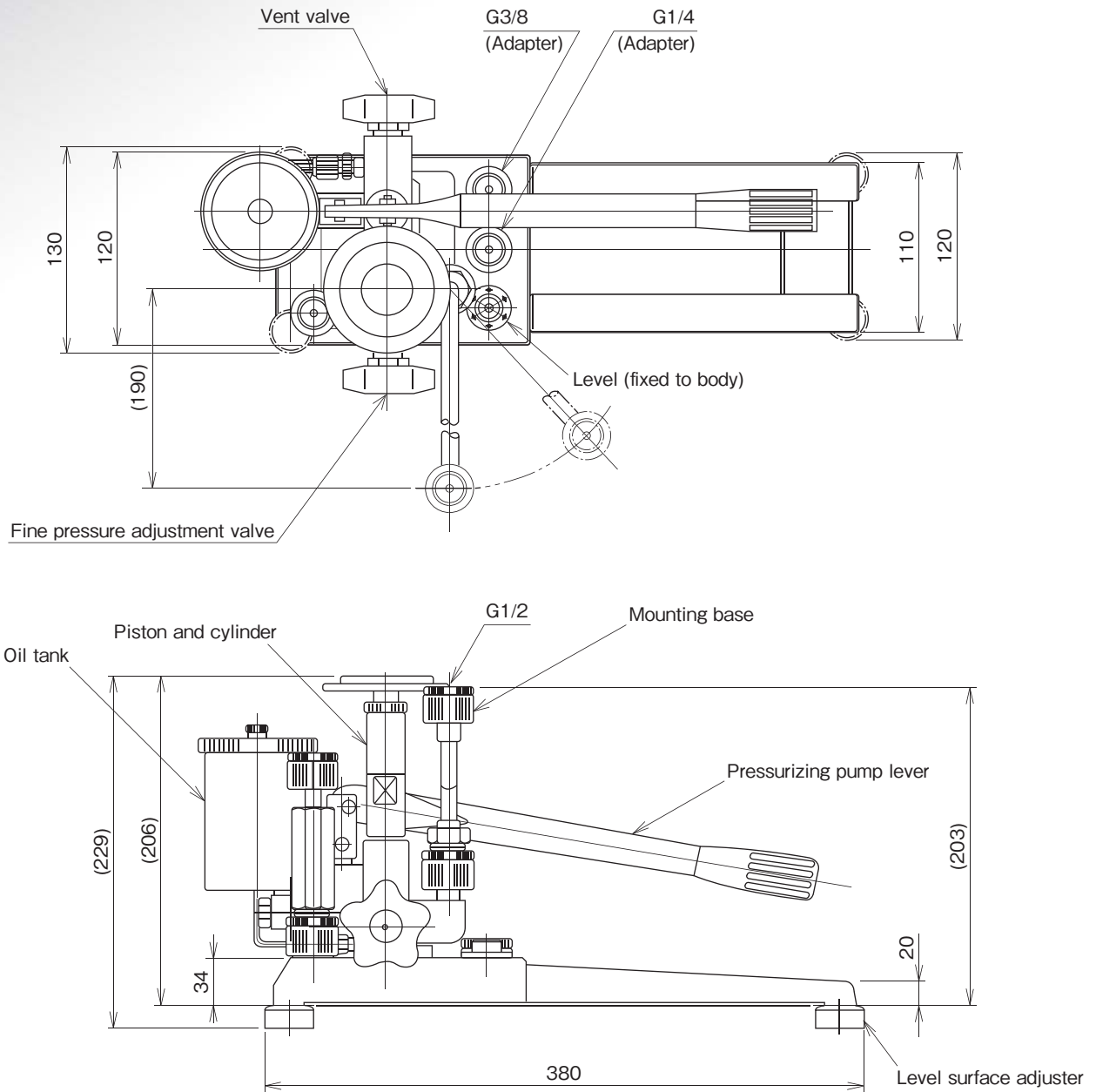

ACCESSORIES & OPTIONS

Model	Mounting base		Spare parts, tools, accessories								
	Connection	Connecting method	Adapte				O-ring and gasket	Piston Gasket	Wrench and other tools	Case (option)	
			G1/4	G3/8	G1/2	G3/4				Carrying case	Weight box
PD73	Adapter	Quick fastening nut	1	1	1	—	P7-10	—	Monkey wrench 1	1 (Standard)	1 to 3MPa 1 ----- 5, 10, 30MPa 2 ----- 20, 50MPa 3

PD73

Portable Type Deadweight Testers

Model number configuration

Please specify the model number, each specs and the range for ordering.

Model

P D 7 3 — **M** **1** — **1** × × × × ×

Deadweight type pressure standard ① ② ③ ④ ⑤ ⑥ ⑦ ⑧ ⑨ ⑩ ⑪ ⑫ ⑬ ⑭ ⑮

Model number		Product specifications		Additional specifications (Optional)		
① Units	M	MPa				
② Accuracy	0	±0.2% O.R. (Body color: Mustard yellow)				
	1	±0.1% O.R. (Body color: Pearl light green) (Except 1MPa and 2MPa)				
(Please specify pressure range and unit of measure along with corresponding ordering code.)	④ Pressure range (MPa)	1	1 ±0.1% O.R. not available		5	10
		2	2 ±0.1% O.R. not available		6	20
		3	3		7	30
		4	5		8	50
⑤ Deadweight finish	3	Ni plating+Carrying case			⑦ Weight box	0
	4	Ni plating+Carrying case+Weight box				1 to 8
⑥ Carrying case	1	Required				
⑦ Weight box	0	Not required		5	With case for 10MPa	
	1	With case for 1MPa		6	With case for 20MPa	
	2	With case for 2MPa		7	With case for 30MPa	
	3	With case for 3MPa		8	With case for 50MPa	
	4	With case for 5MPa				
⑧ Pressure standard inspection / certification	1	Pressure standard inspection (Accuracy: ±0.2% O.R.)				
	3	JCSS certificate of calibration				
	4	Inspection certificate, Traceability certificate (NCSS)				
⑨ Other additional spec.	0	Not required				
	1	Required (Specify required additional specs below) Other units than "SI" (Export purpose only)				
⑮ Documents	0	Not required				
	1	Required (Documents available upon request) Datasheet (Drawing / Specifications) Instruction manual Inspection procedure Attending inspection				

[Remarks] JCSS calibration is not available for the range 1 and 2MPa.

* Specify code "X" to refer N/A

OPERATING INSTRUCTIONS

- Avoid installation in places exposed to excessive vibration, dirt, dust, corrosive atmosphere, and direct sunlight are present.
- Ensure to install the deadweight tester horizontally. If not installed horizontally, the test result may not be accurate.
- Do not try to increase or decrease the pressure suddenly. (Ensure to open and close the valves slowly.)
- Applying a pressure over the maximum allowable pressure on PD73 is not only dangerous but possibly damage the tester.
- The deadweights are precisely manufactured. Do not fabricate with sandpaper or drop them.
- Use a tank siphon to calibrate "Use no oil" pressure gauges and be sure that oil does not ingress into pressure gauge under test.
- Use clean hydraulic oil. Refer to the following operating oil below.

Max. pressure Operating oil

- 1 to 5MPa: Machine oil (VG8)
- 10MPa: Machine oil (ISO VG22)
- 20 to 50MPa: Machine oil (ISO VG46)

Documents

Specify "Document name" when required

Document name	Applicable document	Explanation
Additionally available traceability certificate	Certificate of calibration and inspection for pressure standard used for inspection (Copy)	Copy of certificate that pressure gauge or pressure standard used for the inspection is traceable to National Secondary Standard owned by qualified company.
	JCSS certificate of calibration (Copy)	Copy of certificate of working standard that the working standard is traceable to National Secondary Standard owned by qualified company.
	jcoss test report (Copy)	Copy of certificate of National Secondary Standard that the National Secondary Standard owned by qualified company is traceable to National Standard.

Traceability Chart of Measurement Standard

